

# Digital Conversion Subsystem (DCS-125D)

## Wideband Conversion for Digital IF SATCOM Applications

The Digital Conversion Subsystem (DCS) performs wideband analog-to-digital conversion (ADC) and digital-to-analog conversion (DAC) for Digital IF satellite communication (SATCOM) terminals. The DCS is compliant with the Digital Intermediate Frequency Interoperability (DIFI) standard [IEEE-ISTO 4900-2021]. The DCS transports digitized and encapsulated wideband signals over Ethernet to/from DIFI compatible devices.

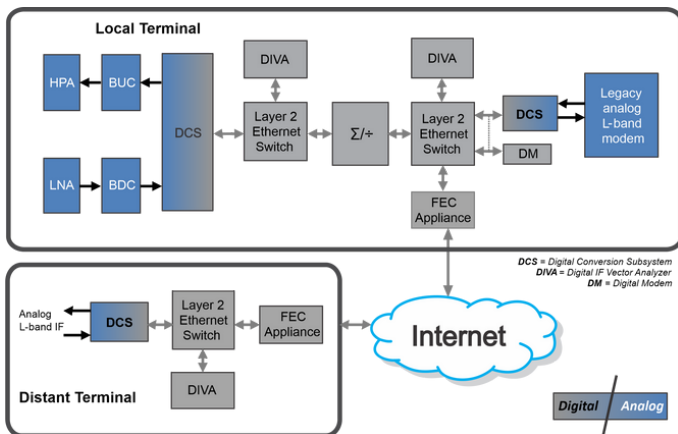

## Features & Benefits

- Compliant with Digital Intermediate Frequency Interoperability (DIFI) standard [IEEE-ISTO 4900-2021]
- Scalable architecture supports multiple antennas/polarities
- Analog L-band interfaces for transmit and receive intermediate frequencies (IFs)
- 10 GbE interface for compatibility with DIFI Devices and COTS Ethernet switches
- 1 GbE SNMP interface for remote monitor and control
- 10 MHz interface for timing and synchronization
- VITA-49 compliant encapsulation of signal samples
- Low spurious and harmonic content (< -40 dBc)
- Negligible implementation loss

## DCS-125D Capabilities

Analog Signal Interfaces	950 to 2150 MHz Transmit and Receive (coax)	Digital Signal Interfaces	10 GbE
Instantaneous Bandwidth	125 MHz Tunable	Timing Interface	10 MHz IN
Broadband Power Levels	-40 dBm to 0 dBm	Sampled Bandwidth	150 Msps to 9.2 Ksps
Dynamic Range	Broadband Transmit and Receive ALC with user-defined set points	Monitor & Control Interface	1 GbE SNMP
Carrier Capacity	Single carrier or composite signal	Chassis	9.5" rackmount, 1 RU Two units side-by-side in 19" rack 8.2"W x 16"D x 1.7"H Wt < 10lbs

## DCS Front Interfaces & Features



DCS Rear Interfaces

1 GbE RJ45 network connector for SNMP status and control

10 GbE SFP+ fiber optic network connectors to Ethernet Switch or WSP

L-band and S-band Type N connector to antenna

For further information on our products,  
contact us at [info@welkinsciences.com](mailto:info@welkinsciences.com).